

# An Absolute Network Energy Efficiency Metric

**Dr. Mike Parker**

**Prof. Stuart Walker**

mcpark@essex.ac.uk

stuwal@essex.ac.uk

**Access Networking Laboratory**

**University of Essex, UK**

Green Grids 2009, Athens, 8<sup>th</sup> September 2009

# Green Telecommunications

---

- Motivations:
  - Environmental (CO<sub>2</sub> footprint)
  - Economic (\$)
  - Practical (battery life of mobile devices)
- Approaches:
  - Power saving strategies
    - Powering down of un-utilised sections of chips & equipment
    - Energy harvesting (e.g. convective currents)
    - Green routing protocols
  - Low-power devices
    - Un-cooled, high-temperature devices - (SiC, GaN) materials
    - Minimise energy dissipation

# Existing Energy-Efficiency Metrics

- **Energy/bit (J/b)**
  - Energy/bit/second (J/b/s)
- **Power/bit (W/b)**
  - Power/bit/second ( $W/b/s \equiv J/b$ )
- **Power Usage Effectiveness (PUE)**
  - Facility's total power consumption/power used only by servers, storage systems & network gear
  - Typically 2.0 (US EPA), aim to achieve 1.7 (by 2011), Google claims 1.21
- **Data-Center infrastructure Efficiency (DCiE)**
  - Equivalent to  $(1/PUE) \times 100\%$
- **Telecommunications Equipment Energy Efficiency Rating (TEEER)**
  - Verizon, Technical Purchasing Requirements, VZ.TPR.9205
  - $-\log(P_{\text{total}}/\text{throughout})$
  - $P_{\text{total}} = 0.35 \times P_{\text{max}} + 0.4 \times P_{\text{ave}} + 0.25 \times P_{\text{sleep}}$

# Nielsen's Law of Bandwidth Growth

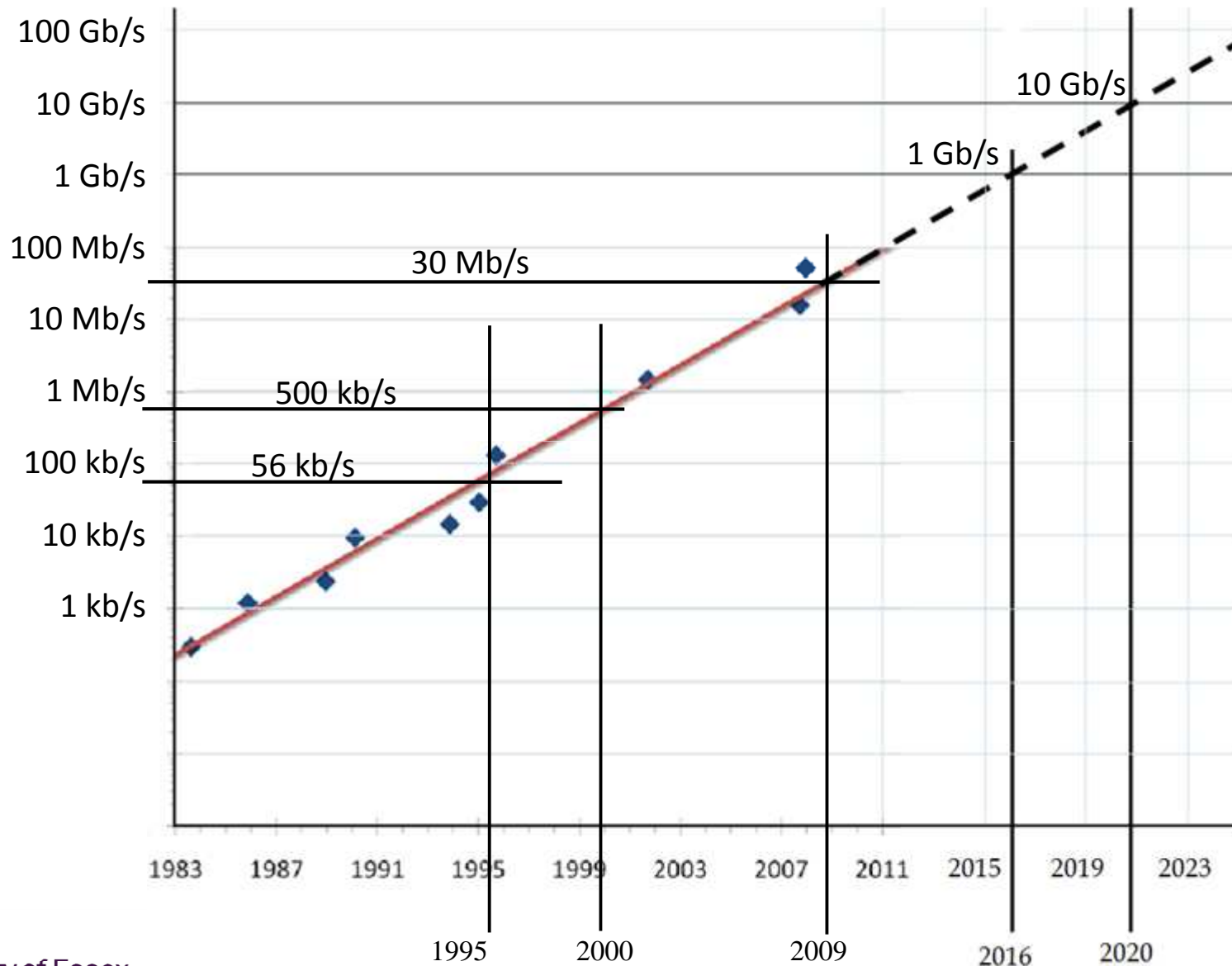

# The Essex University Dept. of Laws

---

- Moore's Law (processing power)
- Nielsen's Law (internet bandwidth)
- Metcalf's Law (network value,  $n^2$  or  $n \log n$ )
- Edholm's Law (converging network technologies)
- Parker-Walker's Law (conservation of network energy)

How to measure network energy consumption?

J/b, J/b/s, W/b, W/b/s...J/b/s/Hz, W/b/s/Hz (spectral efficiency)

What's the minimum J/b for information transmission/processing?

Is there an absolute minimum to network energy consumption?

# Analogy between ICT System and Carnot Heat Engine

## Classical Carnot Heat Engine

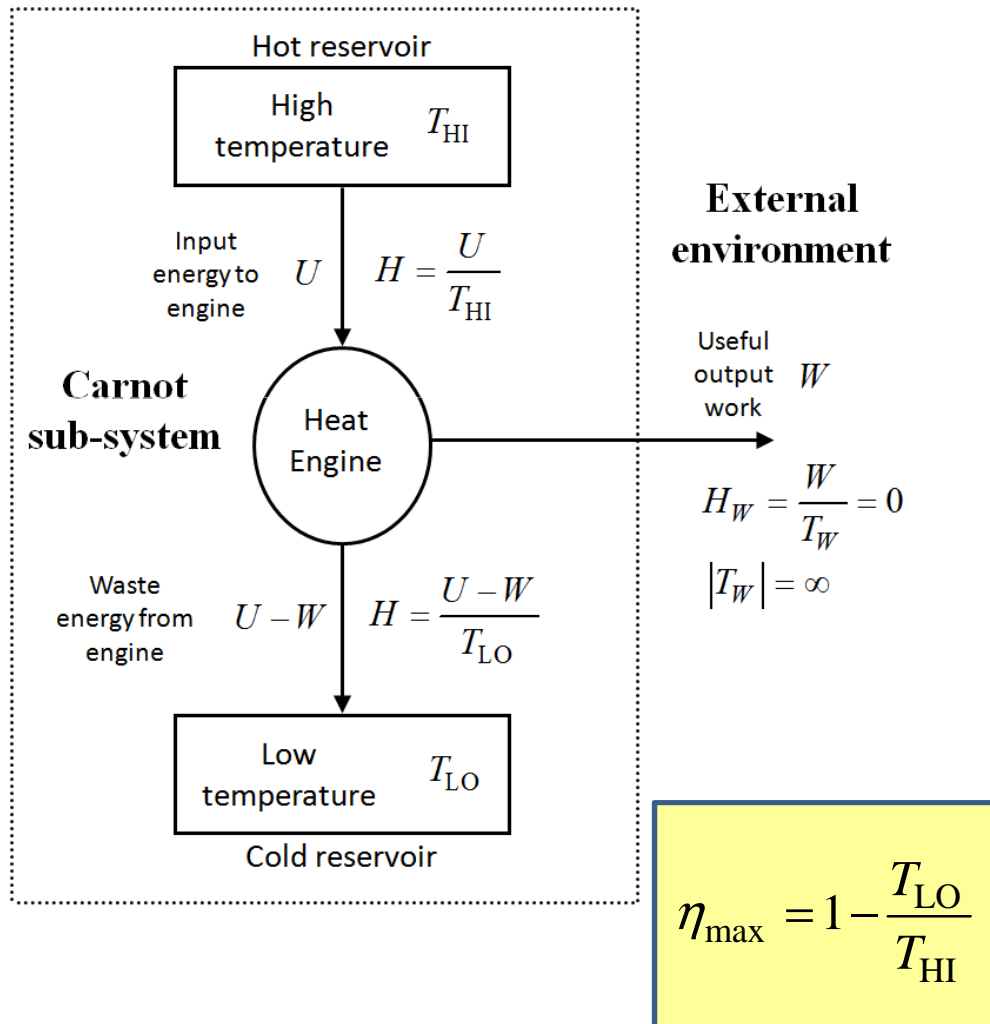

## Analogous ICT system (e.g. PC, data network, Universal Turing Computer)

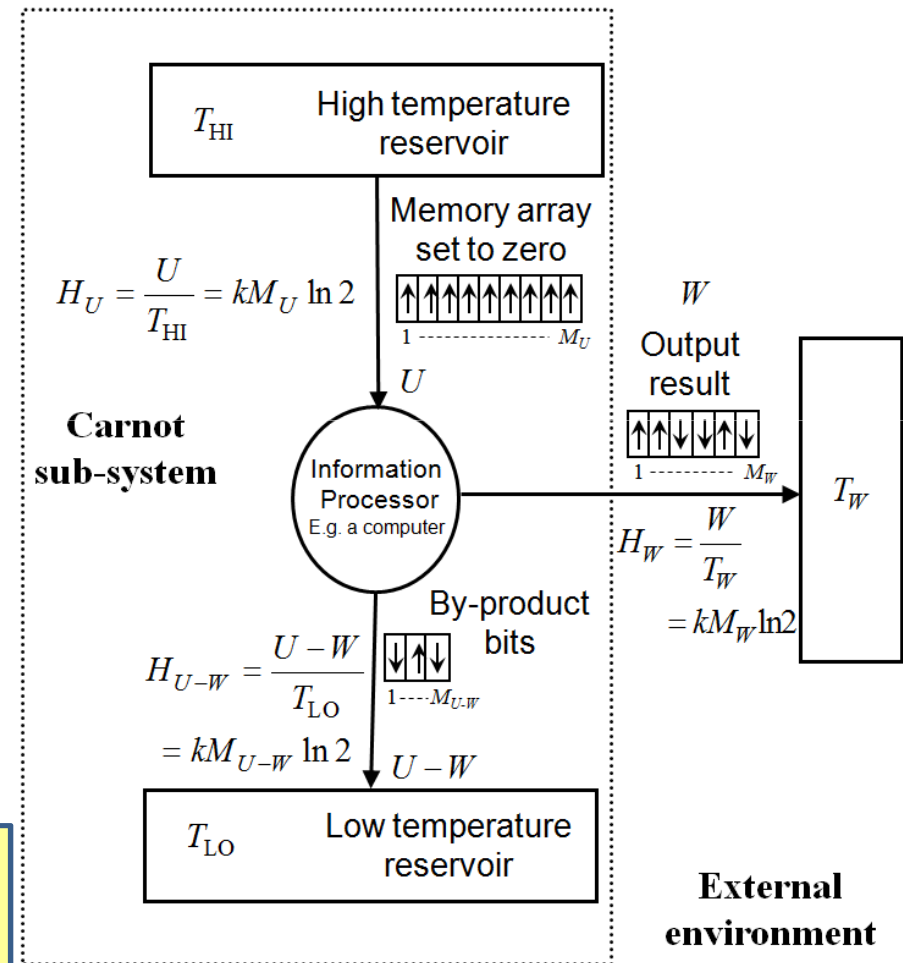

'Differential temperature Carnot heat analysis shows that computing machines are thermodynamically irreversible',  
M.C. Parker, S.D. Walker, *Optics Communications*, 281, p3440-3446, 2008

# Minimum energy to process/transmit a 'bit' of information

Energy dissipated per output bit:

$$\frac{U - W}{M_W} = \frac{1 + T_W / T_{HI}}{1 - T_{LO} / T_{HI}} kT_{LO} \ln 2 \quad [\text{J/b}]$$

Minimum dissipated energy per bit:

$$T_{HI} \rightarrow \infty \quad kT_{LO} \ln 2 \quad [\text{J/b}]$$

c.f. **Landauer's Principle** (energy required to delete a bit of information):

$$kT \ln 2 \quad [\text{J/b}]$$

## Analogous ICT system (e.g. PC, data network)

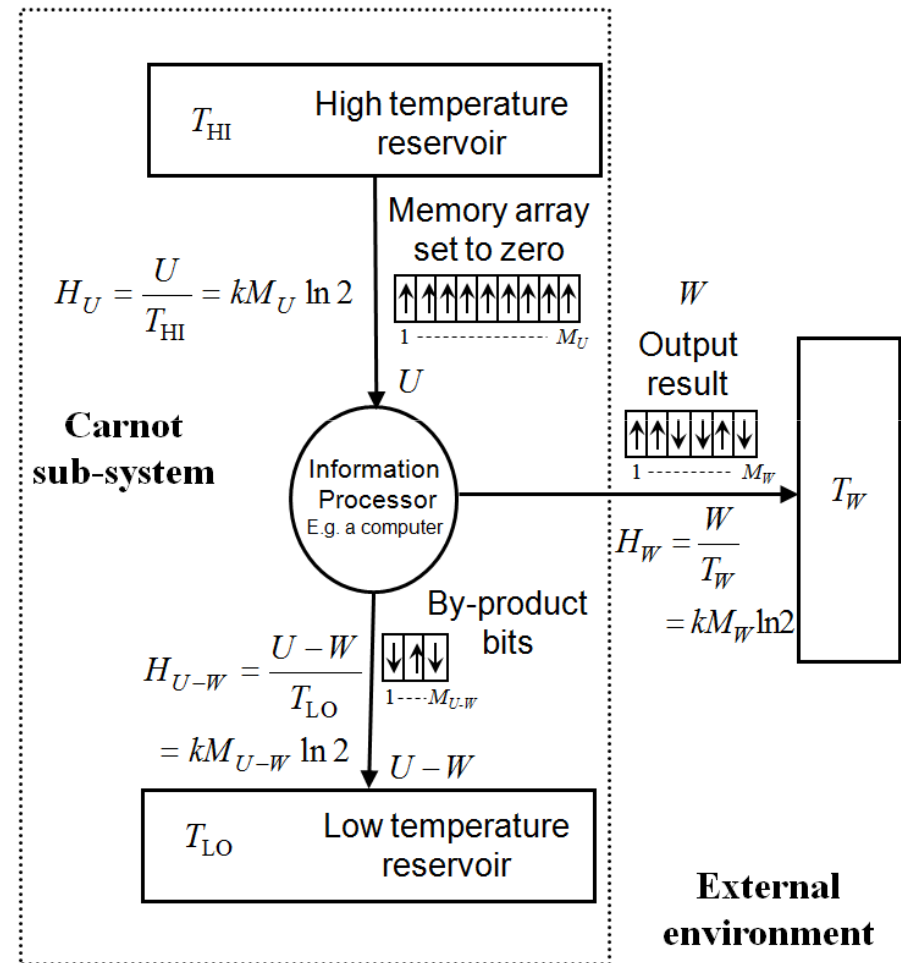

# Absolute Energy Efficiency Figure

$$\text{dB}\varepsilon = 10 \log_{10} \left( \frac{\text{Power/Bit Rate}}{kT \ln 2} \right)$$

Boltzmann's constant  $k=1.381 \times 10^{-23}$  J/K  
 Absolute temperature  $T=300$  K

	Power	Effective bit-rate	Energy/bit [J/b]	dB $\varepsilon$
BT Network	1 GW	22 Tb/s	$45 \times 10^{-6}$	162.0
Dell laptop	80 W	1.87 GHz (clock)	$42.8 \times 10^{-9}$	131.7
Ultra-low power DSL/fibre	165 mW	10 Mb/s	$16.5 \times 10^{-9}$	127.6
Tb/s Router	10 kW	1 Tb/s	$10 \times 10^{-9}$	125.4
200 km Raman-pumped link	60 W	10 Gb/s	$6 \times 10^{-9}$	123.2
Currently most-efficient CPU	2.8 W	1 Gflops	$2.8 \times 10^{-9}$	119.9
Currently most-efficient 10 Gb/s system	10 W	10 Gb/s	$1 \times 10^{-6}$	115.4
Human Brain ( $T=310$ K, or $37^\circ\text{C}$ )	20 W	40 Tb/s	$0.5 \times 10^{-12}$	82.3
20 photons/bit, $10^{-9}$ BER, $\lambda=1.55\mu\text{m}$	25.6 nW	10 Gb/s	$2.56 \times 10^{-18}$	29.5
1 photon/bit, $\lambda=1.55\mu\text{m}$ (quantum limit)	1.28 nW	10 Gb/s	$0.128 \times 10^{-18}$	16.5

# Absolute Energy Efficiency Figure

$$\text{dB}\epsilon = 10 \log_{10} \left( \frac{\text{Power/Bit Rate}}{kT \ln 2} \right)$$

Boltzmann's constant  $k=1.381 \times 10^{-23}$  J/K

Absolute temperature  $T=300$  K

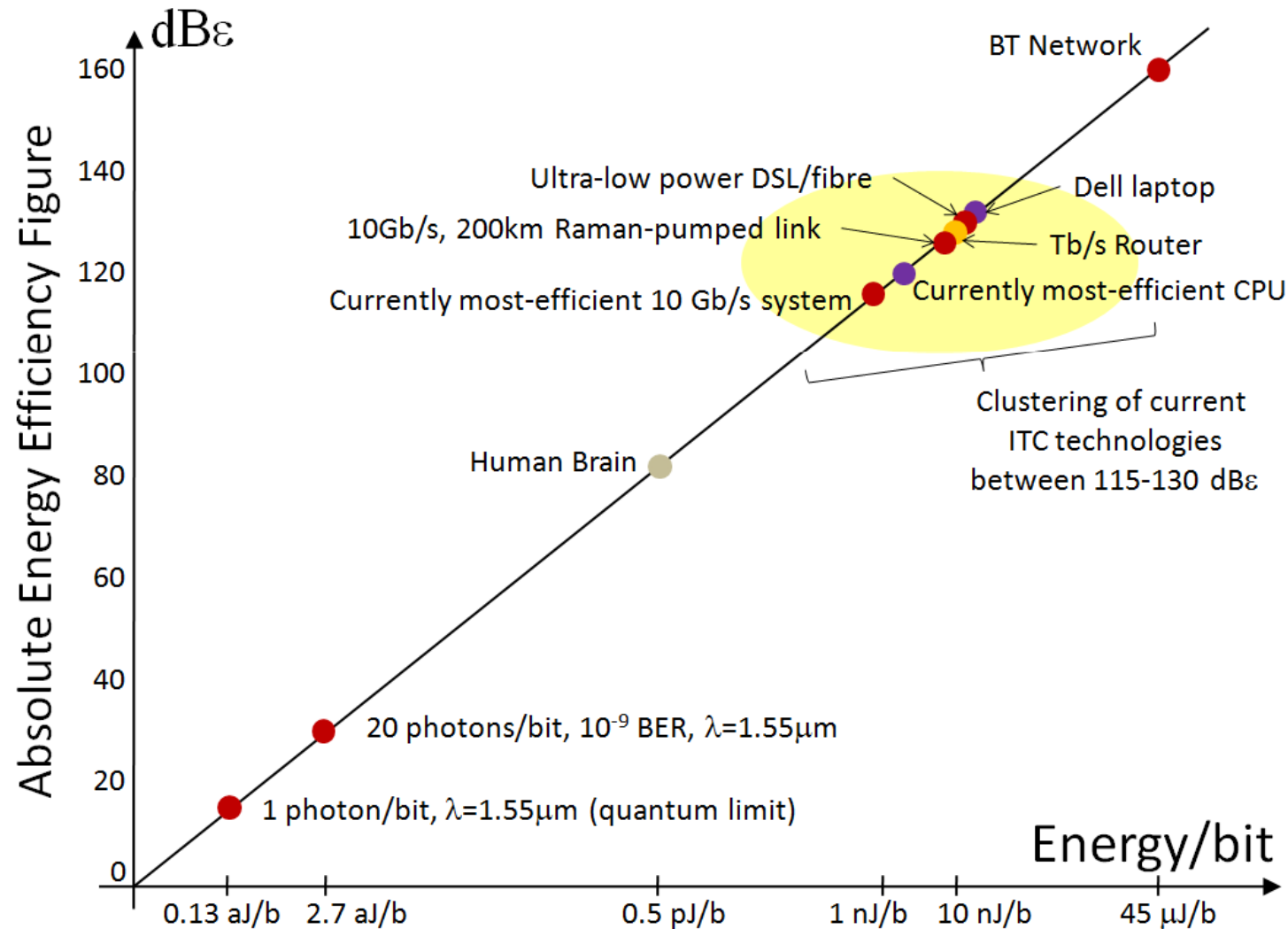

# Green Telecoms: Energy Saving Strategies

---

- Powering down of un-utilised sections of chips (FPGAs)
- Central control to power down un-required equipment
- Energy harvesting (e.g. convective currents)
- “Hot” components
  - No cooling/air-conditioning required
- Green routing protocols
  - IPv6 “green” control bits in header
  - Open Shortest Path First (OSPF)
    - Dijkstra’s Algorithm

# Conclusions

---

## Green Grids, Telecommunications and dB $\epsilon$

- Absolute energy-efficiency metric for CO<sub>2</sub> footprint measurement and comparative studies:
  - dB $\epsilon$  gives lots of insights & a road-map into energy performance
  - More than 30 dB $\epsilon$  (factor x1000) improvement required to reach theoretical efficiency levels of biological information processing systems
  - “Moore’s Law”-type of exponential energy-efficiency doubling every 18 months would achieve 30 dB $\epsilon$  improvements by 2025
- Plenty of networking energy optimisation possibilities:
  - Photonics offers greater energy-efficiency solutions
  - “Hot” chips, components and sub-systems
  - Green routing protocols